

SMR61 Radar Level Meter

RS485 Communication. All-in-One Compact Housing.

The Radar Level Meter is connected directly via RS485 communication interface, providing simple, reliable, cost-saving process data with remote monitoring, calibration, configuration and diagnostic capabilities. Housing in a robust IP68 proof enclosure, 1500 N tensile strength Kevlar reinforced cable, up to 1.2 km digital data transmission, the transmitter is ideally used in water/wastewater industry.

Advantages

- All-in-One Compact Housing, Built-in Transmitter and Sensors
- Robust IP68 Water Submersible Protection, Directly Installed in the Field, No Cabinet Required
- 80 GHz Superior Focusing Radar Beam, Beam Angle Less than 6° to Avoid Obstacles and Build up in Confined Spaces
- 120 dB Wide Dynamic Range to Accurately and Reliably Measure Poorly Reflective Liquides, Liquid down to Bottom level, Even with Surface Foam, Extremely Turbulent Flow, and Condensation on Antenna
- High Resistant PVDF Antenna for Long Service Life in Harsh Environment such us Sewers, Wastewater Treatment Plant, Chemical Tanks
- Advanced Intelligent Algorithm and Signal Processing Technology to Eliminate Echo Noise
- Surcharge Hydrostatic Level Sensor, Continue to Provide Uninterrupted Level Masurement
- Plug & Play, On-line Realtime Measurement
- Ultra Low Power Consumption, Ideal for Outdoor Applications
- 1500 N Tensile Strength Kevlar Reinforced Cable
- Surge Protection for Power and RS485 Communication
- RS485 Digital Communication, Minimize Cabling and Engineering Cost
- Standard Modbus RTU Protocol, Direct Connected with PLC, HMI
- Onboard Memory Allowing Users Easily Calibrate and Configure Sensor at Lab and Distribute to Various Fields Sites
- AQCFG Software Tool for Data Monitoring, Calibration, Configuration and Diagnosis

Applications

Stormwater, surface water, wastewater

Measurement Method

The sensor combines proven radar measurement technology with state-of-the-art spectral signal processing technology to provide a reliable and accurate way to measure level.

Installation

Submersible, flow through, pipe insertion



Specifications

General	
Output Signal	RS485 (Modbus RTU protocol), 19,200 bps, 8 data bits, no parity, 1 stop bit; 4~20 mA
Data Resolution	16 bits (0.001% FS)
Surge Protection	1,500 VDC
Power	5~12 VDC, 0.5 A
Protection	Polarity, Overload, Short circuit
Safety	CE, FCC
Radar Level	
Frequency	80 GHz
Angle	6°
Measurement Range	SMR61-1: 0 ~ 15 m ; SMR61-2: 0 ~ 30 m
Accuracy	±1 mm
Resolution	0.1 mm
Operating Pressure	-1 ~ 3 Kg/cm ²
Operating Temperature	-40~85 °C
Response Time	1 sec
Protection	IP68
Connection	1"-11 PT; M16 plug fixed cable ; M12 connector, 5-pin
Housing Material	POM (housing) ; PVDF (antenna)
Cable	Kevlar reinforced PUR cable, 1500N tensile strength
Dimensions	ø 90 X 204.8(H) mm (no hydrostatic level sensor) ; ø 90 X 243(H) mm (includes hydrostatic level sensor)
Weight	transmitter: approx. 1.2 Kg (no hydrostatic level sensor), 1.5 Kg (includes hydrostatic level sensor); cable: 80 g/m
Hydrostatic Level	
Measurement Range	0~3 m ; 0~10 m (optional)
Accuracy	±0.1% FS (SS316L); ±0.25% FS (Titanium)
Resolution	0.01% FS
Repeatability	±0.025% FS
Stability (annual)	±0.1% FS
Safety Load	3 X measurement range
Rupture	>4 X measurement range
Temperature	
Sensor	Pt1000
Measurement Range	-30~75 °C
Accuracy	± 0.1 °C
Resolution	0.01 °C
Repeatability	0.1 °C

Ordering Codes

Ordering Codes

SMR61 - □ - □ - 005 - 3 - 0 - 0 - □

Measurement Range(m)

0~15 m ————— 1
0~30 m ————— 2

Sensor

None ————— 0
Hydrostatic Level ————— 2
Hydrostatic Level + Temperature ————— 3

Cable Length (m)

5 —————

Cable Type

PUR —————

Housing

POM —————

Wiper

None —————

Wire Connection

Bare Wire ————— 0
M12 Connector ————— 1

Dimensions

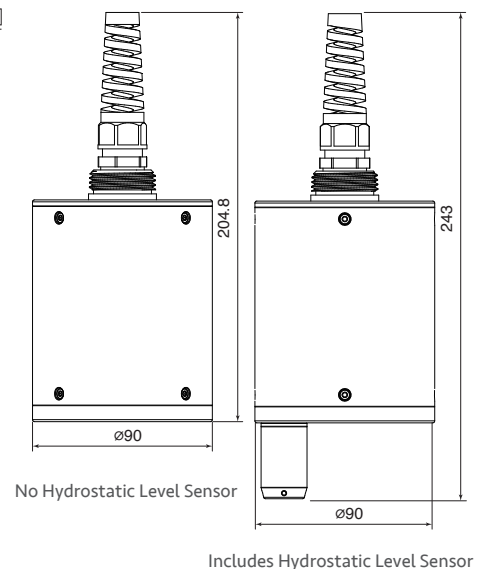

All performances are subject to the actual performance of the products sold by the company in the market, and are only applicable to the products of the company's brand sold by the company or its designated distributors. All the above data are from the internal test of Kaifa Water Resources, and the data may be biased due to different test environments. The manufacturer reserves the right to make changes to product performance, specifications, samples or designs without notice. All information has been carefully checked for accuracy. If there is any printing omission or there may be errors in translation, the company will not be responsible for the consequences.
www.aquas.com.tw



AQUAS Inc.
Taipei Office
Add : 4F.-2, No. 56, Ln. 321, Yangguang St.,
Neihu Dist., Taipei City 11491, Taiwan. R.O.C.
T : +886-2-8797-5358#240
F : +886-2-2657-8926
service@aquas.com.tw

Taichung Office
Add : 5F., No. 190, Dadun 14th St., Nantun Dist.,
Taichung City 408, Taiwan. R.O.C.
T : +886-4-2326-8307