

# SMR45 TOC Analyzer

**RS485 Communication. All-in-One Compact Housing. Explosive Proof.**

Total Organic Carbon (TOC) Analyzer is connected directly via RS485 communication interface, providing simple, reliable, cost-saving process data with remote monitoring, calibration, configuration and diagnostic capabilities. Housing in a robust IP68 proof enclosure, 1500 N tensile strength Kevlar reinforced cable, up to 1.2 km digital data transmission, the transmitter is ideally used in water/wastewater industry.

## Advantages

- All-in-One Compact Housing, Built-in Transmitter and Sensors
- Robust IP68 Water Submersible Protection, Directly Installed in the Field, No Cabinet Required
- Plug & Play, On-line Realtime Measurement
- Ultra Low Power Consumption, Ideal for Outdoor Applications
- 1500 N Tensile Strength Kevlar Reinforced Cable
- Surge Protection for Power and RS485 Communication
- RS485 Digital Communication, Minimize Cabling and Engineering Cost
- Standard Modbus RTU Protocol, Direct Connected with PLC, HMI
- Sapphire Glass Windows to Prevent Scratch
- Innovative Nano Coating to Remain Window Clean
- Auto Cleaning Wiper, Less Maintenance
- Dual Beam Light and Temperature Compensation
- Suspended Solids Measurement and Compensation
- Onboard Memory Allowing Users Easily Calibrate and Configure Sensor at Lab and Distribute to Various Fields and Sites
- AQCFG Software Tool for Data Monitoring, Calibration, Configuration and Diagnosis
- IECEx/ATEX Ex ia IIB T5 Ga Explosive Proof Certification

## Applications

Drinking water, surface water, industry, water treatment, wastewater

## Measurement Method

It is based on fluorescent optical technology. A fluorometer generates the wavelength of light required to excite the analyte of interest, it selectively transmits the wavelength of light emitted, then it measures the intensity of the emitted light. The emitted light is proportional to the concentration of the analyte being measured.

## Installation

Submersible, flow through, pipe insertion



# Specifications

<b>General</b>	
Output Signal	RS485 (Modbus RTU protocol), 19,200 bps, 8 data bits, no parity, 1 stop bit; 4~20 mA (optional)
Data Resolution	16 bits (0.001% FS)
Surge Protection	1,500 VDC
Power	5~12 VDC, 53 mA
Protection	Polarity, Overload, Short circuit
Safety	CE, FCC
<b>TOC</b>	
Measurement Range	SMR45-1 (20 mm) : 0~25 mg/L ; SMR45-2 (5 mm) : 0~250 mg/L ; SMR45-3 (1 mm) : 0~750 mg/L ; SMR45-4 (0.3 mm) : 0~1,500 mg/L ; SMR45-6 (100 mm) : 0~5 mg/L
Accuracy	±5% in standard solution
Resolution	0.01 mg/L
Repeatability	±3% in standard solution
Light Source	LED 254 nm
Beam Angle	180°
Light Path Length	0.3, 1, 5, 20, 50 mm
Process Flow Rate	0.1~10 m/s
Operation Pressure	Max. 10 Kg/cm <sup>2</sup>
Operating Temperature	0~50 °C
Response Time	3 secs
Calibration Interval	Typical 24 months
Protection	IP68
Electrical Connection	M16X1.5 plug fixed cable, M12 connector, 5 pin
Housing	SS316L; Titanium
Cable	Kevlar reinforced PUR cable, 1500N tensile strength
Dimensions	SMR45-1: ø 50X305 mm ; SMR45-2: ø 50X290 mm ; SMR45-3: ø 50X385 mm ; SMR45-4: ø 50X286 mm ; SMR45-6: ø 50X535 mm
Weight	analyzer: approx. 1 Kg; (SS316L); 0.8 Kg (Titanium); Cable: 80 g/m
<b>Suspended Solids</b>	
Measurement Range	SMR45-1 (0~25 mg/L) ; SMR45-2 (0~250 mg/L) ; SMR45-3 (0~750 mg/L) ; SMR45-4 (0~1,500 mg/L) ; SMR45-6 (0~5 mg/L)
Accuracy	±5% measured value
Resolution	0.01 mg/L
Repeatability	±3% measured value

## Ordering Codes

### Ordering Codes

#### Measurement Range(mg/L)

0~25	1
0~250	2
0~750	3
0~1,500	4
0~5	6

#### Sensor

Suspended Solids (SS)+Temperature

#### Cable Length (m)

5	005
10	010
Custom	001~999

#### Cable Type

PUR

#### Housing

SS316L	1
Titanium	2

#### Wiper

Built-in

#### Wire Connection

Bare Wire	0
M12 Connector	1

#### Explosive Proof

None	0
Certificated	1

#### Analog Output

None	0
4~20 mA	1

SMR45 - □ - 3 - □□ - 3 - □ - 1 - □ - □ - □

## Dimensions

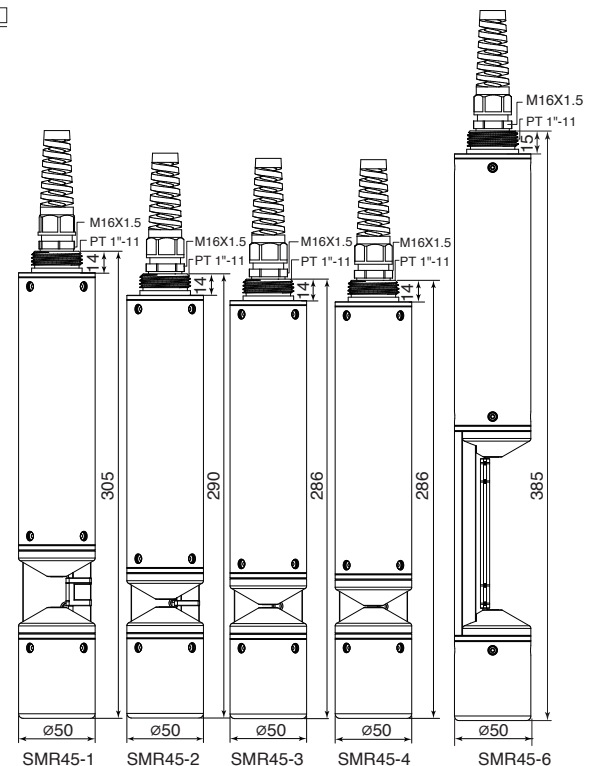

All performances are subject to the actual performance of the products sold by the company in the market, and are only applicable to the products of the company's brand sold by the company or its designated distributors. All the above data are from the internal test of Kaifa Water Resources, and the data may be biased due to different test environments. The manufacturer reserves the right to make changes to product performance, specifications, samples or designs without notice. All information has been carefully checked for accuracy. If there is any printing omission or there may be errors in translation, the company will not be responsible for the consequences.  
www.aquas.com.tw



AQUAS Inc.  
Taipei Office  
Add : 4F.-2, No. 56, Ln. 321, Yangguang St.,  
Neihu Dist., Taipei City 11491, Taiwan. R.O.C.  
T : +886-2-8797-5358#240  
F : +886-2-2657-8926  
service@aquas.com.tw

Taichung Office  
Add : 5F., No. 190, Dadun 14th St., Nantun Dist.,  
Taichung City 408, Taiwan. R.O.C.  
T : +886-4-2326-8307